

MONITOR KEYBOARD

User manual

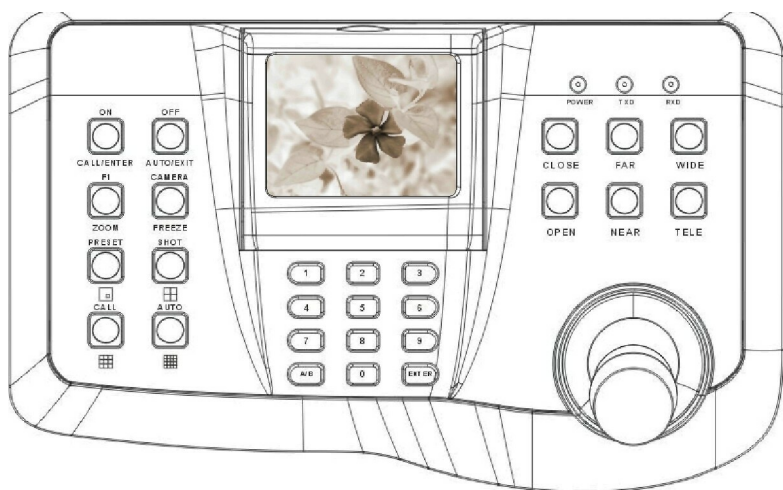

Please read the operation manual carefully
before installing and using this unit

INDEX

1. Important Safeguards	2
2. General Install and connect	3-6
3. Description of functions	7-9
4. Menu setup.....	10-18
5. Appendix.....	19-23

Important safeguards

Note:

- * Read the manual before install and use the keyboard.
- * The product provide some same window information of operation at not same protocol, if the product is not valid function that it will display "NONE VALID" .
- * The monitor keyboard used to DC 12V power supply, check to the voltage and polarity of power-box before use the monitor keyboard.
- * Do not set the monitor keyboard to dank condition, prevent it to trouble.
- * Do not open the product, prevent it to trouble.
- * The keyboard have multi-protocol, right setup protocol, baud rate and ID address before use it, these parameters will display on screen.

General Install and connect

General

The monitor keyboard is a product which can control to demo camera and decoder. Used to EIA/RS-485 import between keyboard and demo camera. One keyboard can control 256 demo camera at best, the most communication distance is 2.4Km. end device can be set and controlled easily with keyboard,. Front device such as constantspeed pan/tilt, lens, lamplight, water-brush can be controlled also with keyboard by directly control decoder.

Install and connect

Please read user manual of high speed dome camera carefully before connection. Device may be damaged forever with any error connection. Please shut off power before connection . use STP line to connect between device and device . Avoid from high voltage line or any possibly disturbed line as soon as possible when connecting cable.

Install and connect

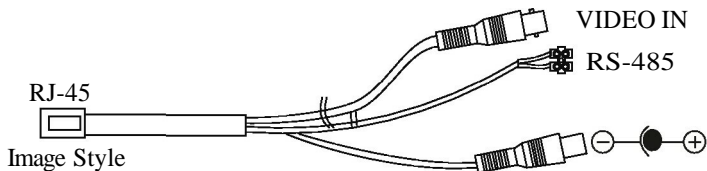
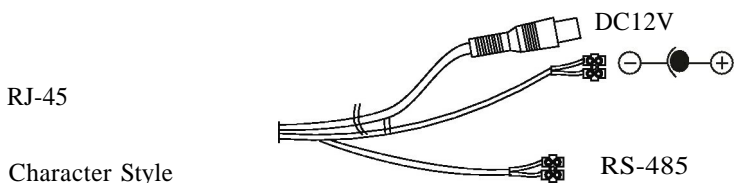
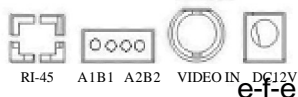
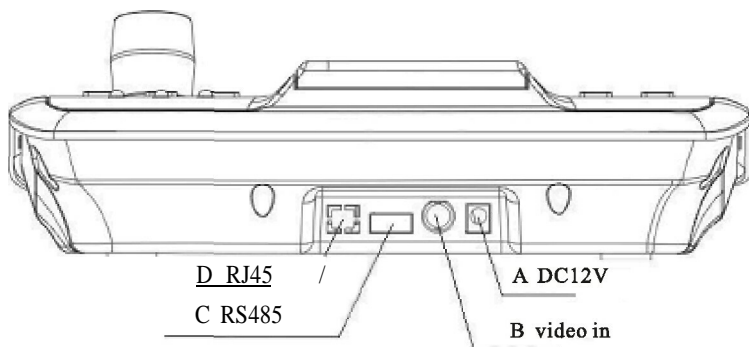

Red: CH1 RS485+/A1
 Black: CH1 RS485-/B1
 Yellow: CH2 RS485+/A2
 Green: CH2 RS485-/B2

Figure1

Install and connect

Figure 1 is the keyboard interface, include power in ,video in(used in 3.5inch LCD keyboard),RS485 communication interfaceand special interface.

A.Power supply import: used to DC12V/1A

B.Video import: IV-pp

C.RS485 communication import

D.RJ45: system reserve

E.Fence port is RS485 connection .If select special interface linewhich supply by engender, please refer to information of labelto connect.

Install and connect

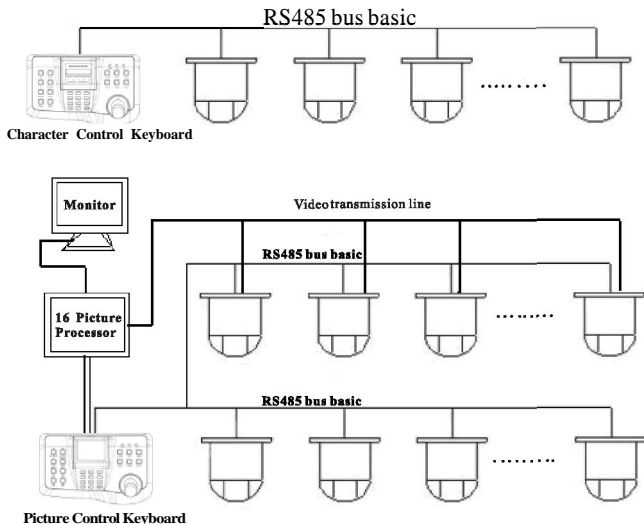

Figure 2

Figure 2 is the connection of the two keyboard each. Picture Control Keyboard can work with the multivision plus processor, control it at long distance, and show image itself also. At figure 2 , the thick line is video line and the thin line is RS485 line.

If use cable of connection, depend on label to connection cable.

The communication mode between keyboard and demo speed camera: dot to multi-dot, semiduplex communication.

Communication import: RS485.

Baud rate : 1200Bps,2400Bps,4800Bps,9600Bps, 19200Bps.

Communication distance:2.4km(Max)<

Power supply: DC12/1A₀

Control number of demo camera: 256 (Max)o

Description of Functions

Function

Character Control Keyboard

- Setup demo camera or decoder ID address range: 0~255.
- Control to multi-function of demo camera, such as: menu, focus, white balance.
- control the demo camera to multi-speed.
- Save preset position of demo camera, setup shot about the preset position. The keyboard can setup 8 shots, each shot can save 16 preset position.
- Two control mode: manual mode and auto mode.
- control zoom, focus and iris of demo camera by manual mode.

Picture Control Keyboard

- Picture Control Keyboard can show image, and the other functions are same as the Character Control Keyboard. It can work with multivision plus processor and control it at long distance.

Panel introduce

1. front panel introduce (figure 3)

Description of Functions

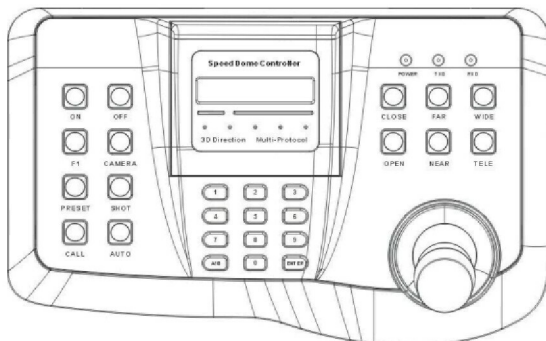

figure 3 Character control keyboard panel

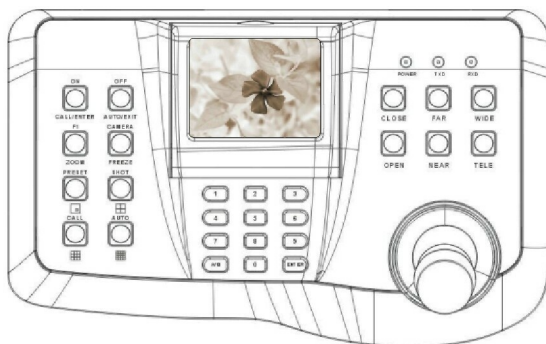

figure 3-1 Image control keyboard panel

Component of front panel:

3D multi-speed rocker, keyboard, 16x2 LCD of character or 3.5 inch screen of image, LED light. Keyboard note:

[ON] open to function setup

[OFF] close to function setup

[F1] aux-keyboard

[CAMERA] setup demo camera ID address

Description of Functions

[PRESET] save to preset position

[SHOT] call shot of demo camera

[CALL] call preset position

[AUTO] auto run demo camera

[0]~[9] number keyboard

[A/B] Swap key and clear number key

Swap key: swap general A key to multivision plus processor B key, It is default general A key (type name on key) after power on. Press the [A/B] key to multivision plus processor B key (type name below key). Press again the [A/B] key return to general A key.

[ENTER] enter keyboard

[CLOSE] reduce iris

[FAR] focus far

[WIDE] zoom out

[OPEN] increase iris

[NEAR] focus near

[TELE] zoom in

On the Picture control keyboard, the key operation of image processor please refer to the manual of the image processor.

Menu setup

2. Protocol list and baud rate list

Protocol	Baud rate(default)	protocol	Baudrate(default)
PELCO-D	2400	KALATEL	4800
PELCO-P	9600	VCLDOME	9600
PELCO-P	4800	REDAPPLE	9600
VIDO-BO1	9600	HTSCAM	9600
LILIN	9600	SAMSUNG	9600
ALEC	4800	SANTACHI450	9600
HD600	9600	SANTACHI650	9600
TOTA	4800	VICON	4800

Press F1 +61+ON, F1 +62+ON to change protocol and baud rate,about content see List 2

3. Operation introduce

The keyboard controller must connected to demo camera and right setup ID address before operation. Then turn on power that it will display at bellow:

```
PELCOD 2400  
Camera ID: 000
```

PELCOD: current protocol

2400: current baud rate

000: current demo camera ID

3.1 Setup demo camera id address:

[CAMERA]+[N]+[ENTER]

Display:

```
CHANGE CAMERAID  
Camera ID: N
```

Note: N---ID address, range:0~255

Function: setup demo camera ID address.

3.2 Aux-function setup

Enter menu of aux-function: [F1] + [ON]

Display:

FUNCTION MENU
CHANGE PROTOCOL

Note: press [WIDE] / [TELE] to select menu, press [ENTER] in to item.

Option such as change protocol ,change baud rate, change LCD back light (character) or expand monitor (image) and so on has be supplied at present. Expand monitor function is used when user need connect video with keyboard and connect it with monitor or image procession at the same time .When only connect with keyboard, select "CHANGE MONITOR S" ; when connect with monitor or other at the same time, select " CHANGE MONITOR M" .

Direct in to aux-function setup: [F1] +[N] + [ON]

Note 1: see List 2 about N value

Note 2: [F1] +[61] + [ON] for change protocol,

[F1] +[62] + [ON] for baud rate

Menu setup

3.3 Save preset position: [PRESET]+[N]+[ENTER]

Display:

PRESET FUNCTION

PRESET: N

Note: N---position, range: 1~255

Function: save the position of DEMO camera

3.4 Call preset position: [CALL]+[N]+[ENTER]

Display:

PRESET FUNCTION

CALL: N

Note: N---the number of preset position, range: 1~255

Function: call the position of DEMO camera to run direct

3.5 Clear preset position: [PRESET]+[N]+[OFF]

Display:

PRESET FUNCTION

PRESET: N

Note: N--- preset position, range: 1~255

Function: clear the number of current position

3.6 Setup shot of preset position

Note: the function is only used at VEDIO-BO1

3.6.1 Enter to item of setup shot:

[SHOT] + [N] + [ON]

Display:

```
SHOTOPERATION
Track 01 Sum 07
```

Note: the current setup is 1 shot, it contains 7 preset positions

3.6.2 Edit shot:

press [ENTER] into status of editing shot, press [TELE] to ahead edit, press [WIDE] to backward edit. Each shot contain 16 preset positions and each a preset position can setup to speed or time of pause.

Display:

```
EDIT SHOT
NO.:01 Point:01
```

Note: select 01 preset position in first shot.

Menu setup

Display:

```
EDIT SHOT  
NO.:01 Speed:02
```

Note: select 2 step speed in 01 preset position.

Display:

```
EDIT SHOT  
NO.:01 Time:03
```

Note: select 3 seconds for pause time of 01 preset position.

Note:

- a. Speed range: 1~8, the first step speed is the most slow, the eighth step speed is most flash speed. The speed will be defaulted 1 step if speed range is over. Pause time range: 1~255.
- b. If the preset position, speed and pause time is not defined that these parameter is defined to 0.
- c. Press OFF key to exit when finishing the shot setup, the parameter will be not saved if you are operation to joystick while setup the parameter.
- d. Some high speed dome camera can set track on menu, detailed operation look at user manual of high speed dome camera.

3.7 Run shot: [SHOT]+[N]+[ENTER]

Display:

SHOT OPERATION
Running N SHOT

Note: N--- number of shot, range: 0~8

Function: run to selecting shot.

3.8 Stop to shot mode: [SHOT]+[OFF]

Function: stop the state of shot running, the shot mode will be stop when operation joy stick.

3.9 Run the state of plane scan: [AUTO]+[ON]

Display:

Scan Operation
Auto Running

Function: run the state of plane scan for 360 degree monitor.

3.10 Top the state of plane scan: [AUTO]+[OFF]

Function: run the state of plane scan for 360 degree monitor.

3.11 Control camera to zoom: [WIDE]/ [TELE]

3.12 Control camera to focus: [FAR] / [NEAR]

3.13 Control camera to iris: [OPEN]/ [CLOSE]

Menu setup

List2 Aux-function about+N+ENTER

N Number	control item	define	
		[F1]+N+{ON}	[F1]+N+{OFF}
0	camera power supply	Turn on	Turn off
1	backlight compensate	ON	OFF
2	zero illumination	ON	OFF
3	menu	ON	OFF
4	digital zoom	ON	OFF
5	keyboard backlight	ON	OFF
6	focus	Auto	manual
7	iris	Auto	manna
8	white balance	Auto	manual
9		indoor	outdoor
10		ATW	onePush
11	Color/black-white	color	white
12	speed of line scan	less than 180C, low speed	more than 180C, low speed
13	direction of line scan	less than 180C, mid speed	more than 180C, mid speed
14		less than 180C, highspeed	more than 180C, highspeed
61	Change protocol	enable the function	disable the function
62	Change band rate	enable the function	disable the function

Notice: what introduce is some common operation function, but not all protocol and end device have this, such camera that not supply night /day can not switch between black and color .Operation that protocol not supply will show "NONE VALID " .

4 . Multi-speed rocker controls the DEMO camera under 3 figure:

- The direction of DEMO is controlled by press rocker to UP, DOWN.RIGHT or LEFT.
- The direction of DEMO is controlled by press angle of rocker at same direction.
- The DEMO camera will focus automatically so that figure of camera is clear all along.

Menu setup

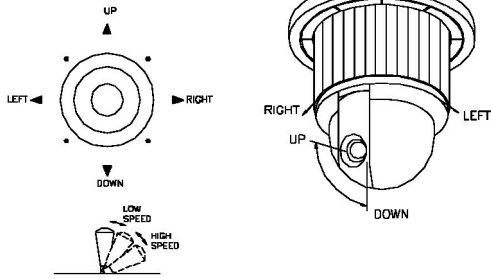

Picture Control Keyboard can show image, and other functions are same as the Character Control Keyboard. It can work with multivision plus processor and control it at long distance.

Press the key A/B once to switch to image processor mode or to normal mode, on image processor mode, showing as bellow:

```
PELCO * 9600
```

```
Camera ID: N
```

Display " * " between protocol and baud rate. Press A/B again to cancel image processor mode. On image processor mode:

Press [ENTER]+0+[ENTER], into image processor functional menu.

Press [ENTER]+N+[ENTER], into the N input video, N=1-16

With [CALL/ENTER], [AUTO/EXIT], [ZOOM]. [FREEZE], [one image] key ,[four image] KEY, [nine image] KEY and [sixteen image] key, other operation can be done. The key function is same as image processor panel. The function and the operation refer to manual of image processor.

Specification list

Screen display	16x2 character	3.5"LCD color picture
Control object	High speed ball , general ballPTZ decode	High speed ball ,general ball PTZdecode, 16picture processor
Protocol	PELCO-D , PELCO-P	
	ALEC , SAMSUNG	
	VIDO-B01.NEON	
	HTSCAM	
	HD600,TOTA	
	KALATEL ,VCLDOME	
	REDAPPLE.SANTACHI450	
	SANTACHI650.VICON	
Baud rate	1200bps,2400bps,4800bps,9600bps,19200bps	
Out channel	2 channel	
Communication distance	Max :2400m	
Operation Temperature	-10-C-50-C	
Power	DC12V/1A	DC12V/1A

Appendix

1. Lighting proof and surge signal proof

The product adopts TVS lightning proof technology to prevent from damage by lightning strike below 1500 W and impulse signals such as surge; but it is also necessary to abide by the following precautions to ensure electrical safety based on practical circumstances:

- * Keep the communication cables at least 50 meters away from high voltage equipment or cables.
- * Make outdoor cable laying-out under eaves as possible as you can.
- * In open area shield cables in steel tube and conduct a single point ground to the tube. Trolley wire is forbidden in such circumstances.
- * In strong thunderstorm or high fardic zone (such as high voltage transformer substation), extra strong lightning proof equipment must be installed.
- * Take the building lightning proof requirements into account to design the lightning proof and grounding of outdoor equipment and cable laying-out in accordance with the national and industrial standards.
- * The system must be grounded with equal potentials. The earth ground connection must satisfy the anti-interference and electrical safety requirements and must not short circuited with high voltage electricity net. When the system is grounded separately, the resistance of down conductor should be <4 ohm and the sectional area of down conductor should be $<25\text{mm}^2$.

Appendix

2 RS485 bus basic knowledge

2.1 Characteristics of RS485 Bus

As specified by RS485 standards, RS485 Bus is of half-duplexed data transmission cables with characteristic impedance as 120 W . The maximum load capacity is 256 unit loads (including main controller and controlled equipment).

2.2 Transmission distances of RS485 Bus

When user selects the 0.56mm (24AWG) twistedpair wires as data transmission cable, the maximum theoretical transmitting distances are as follows:

Baud RateMaximum	Transmitting Distance
1200 Bps	2400m
2400 Bps	1800m
4800 Bps	1200m
9600 Bps	800m
19200 Bps	200m

If user selects thinner cables, or installs the dome in an environment with strong electromagnetic interference, or connects lots of equipment to the RS485 Bus, the maximum transmitting distance will be decreased. To increase the maximum transmitting distance, do the contrary.

Appendix

2.3 Connection and termination resistor

The Rs485 standards require a daisy-chain connection between the equipment. There must be termination resistors with $120\ \Omega$ impedance at both ends of the connection.

(refer to Picture 37). Please refer to Picture 38 for simple connection. "D" should exceed 7m.

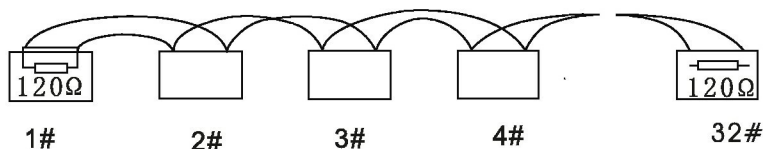
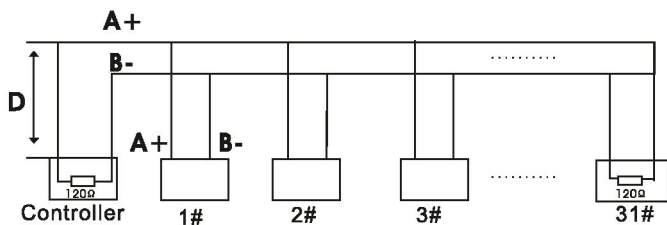

Figure37



FigureS8

Appendix

2.4 Problems in practical connection

In some circumstances user adopts a star configuration in practical connection. The termination resistors must be connected to the two equipment that are farthest away from each other, such as equipment 1# and 15# in Picture 44. As the star configuration is not in conformity with the requirements of RS485 standards, problems such as signal reflections, lower anti-interference performance arise when the cables are long in the connection. The reliability of control signals is decreased with the phenomena that the dome does not respond to or just responds at intervals to the controller, or does continuous operation without stop (refer to Picture 39)

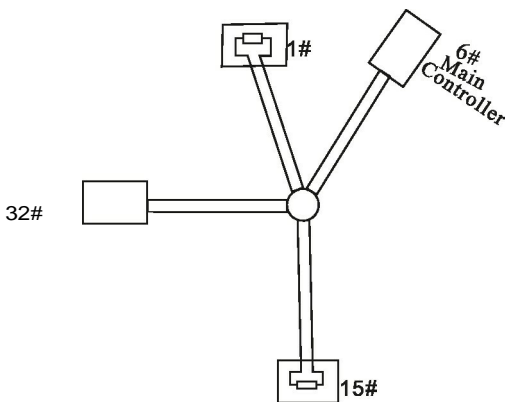

Figure 39

In such circumstances the factory recommends the usage of DR-HB 16 RS485 distributor. The distributor can change the star configuration connection to the mode of connection stipulated in the RS485 standards. The new connection achieves reliable data transmission (refer to Picture 40).

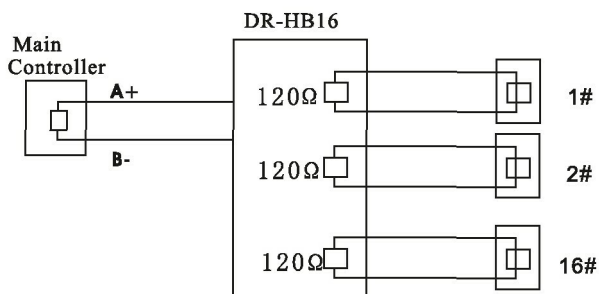

Figure40

PAP-MC006EA10